



SHRI RAJESHWARI
Industrial Essentials

Authorised Dealer



AN ISO 9001-2008
CERTIFIED COMPANY



IDLERS & ROLLERS

www.shrirajeshwariindustries.com



ABOUT OURSELVES

KIC is one of the leading designers and manufacturer of various types of bulk and package handling conveyors and system and their components like idlers Drums, Pulleys etc.

KIC has designed and manufactured Idlers in different Troughening Angles and for various usages for a wide range of belt conveyors. The range include fixed carrying type, fixed Return type and garland type and for different belt width.

KIC Idlers, Drive Drums ensure quality and tail end pulleys ensure quality and performance manufactured as per Latest I. S. Specification.

Latest Design and Robust Construction Idlers Drums & Pulleys Produced by 'KIC' ensure efficient material handling for various industries. The Idlers and drum available in different ranges having employed modern 'Ste-of-the-art' Technology to fulfil the expectation of esteemed clients. They bear the testimony of strength, quality & class through proven trial.

More so, the latest design of KIC idlers/Roolers/Drum Pulleys ensure smooth, friction less movement of the conveyors to withstand trying conditions and they minimize undue maintenance cost and time.

One source of product
 One source of service
 One source to assume entire
 Responsibility of your installations.
THAT IS
 Khodiyar Industrial Corporation.

Core Value

- Transparency <<
- Customer First <<
- Respect for All <<
- Commitment <<
- Team Work <<
- Continuous Improvement <<

Goal

To be the "TATA" of our business and build Rs. 300 Cr. Group by 2030.

Parts



ERW Pipe

High Speed Conveyor Tube
In Accordance to IS-9295
Outer dimension variation
 ± 0.2 mm for $\varnothing < 133$ mm
 ± 0.3 mm for $\varnothing > 133$ mm
Wall thickness variation
 $\pm 10\%$ applicable
In line eddy Curerent tested

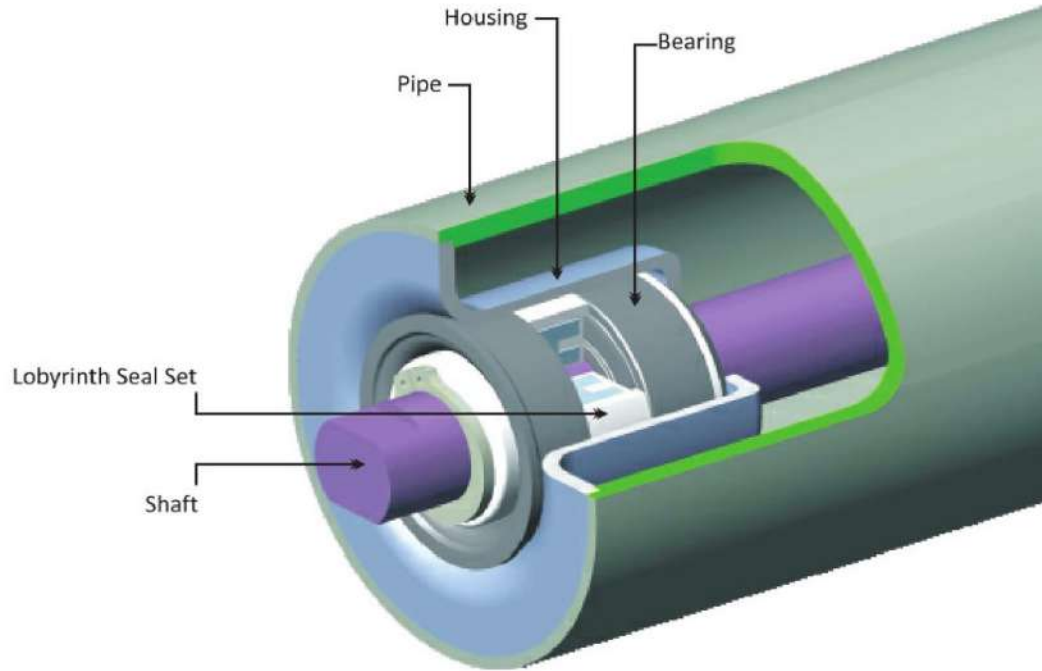

Housing

CNC Treated to ensure both :
- Proper fit of sheel ends to bearing housing
- Excellent grip and positioning of bearing inside the bearing housing
- Tolerance + 0.00. - 0.027 mm



Housing Labyrinth Seal Set

- 1) Sealing Ring (Material: Nylon)
- 2) Female Labyrinth Sealing Ring/inner Seal (Material: Nylon)
- 3) male Labyrinth sealing ring/Outer Seal (Material: Nylon)
- 4) Metal cap/Dust Cap (Material: Steel)
- 5) protective cap/Rain Cap (Material: Nylon)



Shaft

Cold Drawn Bright Shaft Bar
Tolerance $\pm 0.0 - 0.03$ mm



Bearing (Ball Bearing)

62xxZZ / RS
63xxZZ / RS

Carrying Idlers



- a. Troughed Carrying Idler.
- b. Flat Carrying Idlers.
- c. Troughing Carrying Idler (Off-Set)
- d. Training Carrying Idlers.

Return Idlers



- a. Plain Return Idlers.
- b. Self-cleaning rubber disc return idlers.
- c. Self-cleaning helical return idlers.
- d. Training return idlers.
- e. 'V' type return idlers.
- f. Rubber ring impacts return idlers.

HDPE Roller



- a. Troughed Carrying Idler.
- b. Flat Carrying Idlers.

Impact Idlers



- a. Rubber disc impact idlers.
- b. Rubber lagged impact idlers.
- c. Garland impact idlers.
- d. Training impact idlers.

Self Aligning Idler



- a. Self Aligning Return Idler
- b. Self Aligning Carrying Idler

Garland Idlers



- a. Garland carrying idlers
- b. Garland return roller with brackets
- c. Suspended Sets

Conveyor Pulleys



- a. Head Pulleys
- a. Tail Pulleys.
- b. Snub Pulleys.
- c. Tension Pulleys.
- d. Bend Pulleys

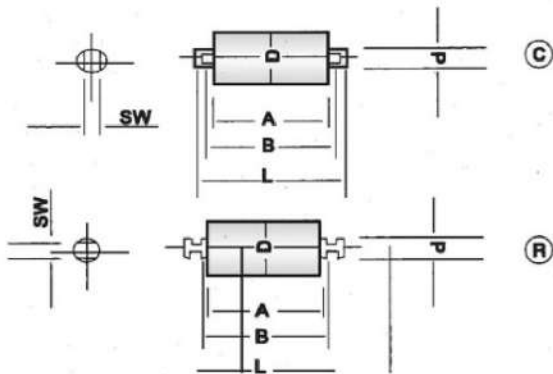

SERIES - KIC 204
STANDARD - IS : 8598 / 4776
TUBE DIA & THICKNESS AS PER IS : 9295

			L	M	H	E.H.
1)	88.9	dia	- 3.25	4.05	4.85	-
2)	114.3	dia	- 3.65	4.5	5.4	6.3
3)	139.7	dia	- 4.5	4.85	5.4	6.3
4)	165.1	dia	- 4.5	4.85	5.4	6.3
			d	=	20 mm	
			sw	=	14 mm	

All dimension are in mm.

SERIES : KIC : 6204 / 420204

Belt Width	Roller Dia.	Flat Top / Return Idler					2 Roll Top Idler					3 Roll Top Idler				
		Dimension in mm			Wt. In Kg.		Dimension in mm			Wt. In Kg.		Dimension in mm			Wt. In Kg.	
		A	B	L	Rotating Parts	Total	A	B	L	Rotating Parts	Total	A	B	L	Rotating Parts	Total
400	88.9	500	508	536	5.6	7.1	250	258	276	3.5	4.2	160	168	186	2.6	3.2
	114.3				7.6	9.0				4.5	5.3				3.5	3.9
450	88.9	550	558	586	6.0	7.7	290	298	316	3.8	4.7	180	188	206	2.9	3.4
	114.3				8.1	9.8				5.0	5.9				3.7	4.2
500	88.9	600	608	636	6.4	8.3	315	323	341	4.0	5.0	200	208	226	3.0	3.6
	114.3				8.8	10.6				5.3	6.3				3.9	4.5
600	88.9	700	708	736	7.3	9.4	350	358	376	4.3	5.3	235	243	261	3.3	4.0
	114.3				10.0	12.0				5.7	6.8				4.3	5.0
650	88.9	750	758	786	7.7	10.0	380	388	406	4.6	5.7	250	258	276	3.4	4.2
	114.3				10.6	12.9				6.1	7.3				4.5	5.3
750	114.3	850	858	886	11.8	14.3	415	423	441	6.5	7.8	290	298	316	5.0	5.9
	139.7				14.4	17.0				8.5	9.7				6.4	7.5
800	114.3	950	958	998	12.0	16.6	465	473	491	7.1	8.9	315	323	341	5.3	6.5
	139.7				15.9	19.5				9.3	11.0				6.8	8.0
	165.1				20.3	23.9				11.0	12.7				8.0	9.2
900	114.3	1050	1058	1098	14.2	18.2	530	538	556	7.9	9.9	350	358	376	5.7	7.0
	139.7				17.4	21.4				10.3	12.3				7.4	8.7
	165.1				22.2	26.2				12.2	14.2				8.8	10.0
1000	114.3	1150	1158	1198	15.4	19.8	600	608	626	8.8	11.0	380	388	406	6.1	7.5
	139.7				18.9	23.3				11.5	13.7				7.9	9.3
	165.1				24.1	28.5				13.5	15.8				9.3	10.7

*1. Belt Width not covered under IS.

2. Rollers with 76.2 mm. 101.6 mm. 127 mm & 152.4 mm. Dia can be made as per Customers specific requirement.

3. Impact Idlers will have rubber Rings (Shore Hardness 65°±50°) press fitted on the Ø76.1, 88.9 / 114.3 dia tube and locked at both ends.

4. Weight of Roller based on medium duty tube.

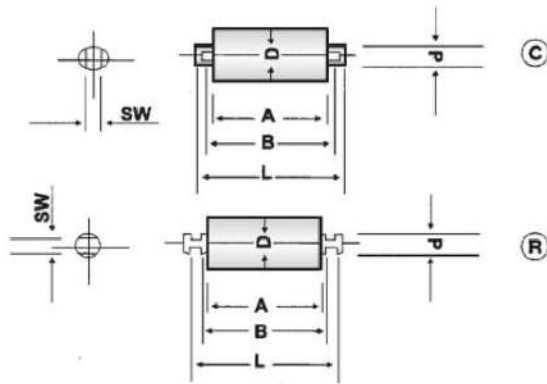

SERIES - KIC 205
STANDARD - IS : 8598 / 4776
TUBE DIA & THICKNESS AS PER IS : 9295 / 12.39

			L	M	H	E.H.	
1)	88.9	dia	-	3.25	4.05	4.85	-
2)	114.3	dia	-	3.65	4.5	5.4	6.3
3)	139.7	dia	-	4.5	4.85	5.4	6.3
4)	165.1	dia	-	4.5	4.85	5.4	6.3
				d	=	25 mm	
				sw	=	18 mm	

All diamention are in mm.

SERIES : KIC : 6205 / 420205

Belt Width	Roller Dia.	Flat Top / Return Idler					2 Roll Top Idler					3 Roll Top Idler				
		Dimension in mm			Wt. In Kg.		Dimension in mm			Wt. In Kg.		Dimension in mm			Wt. In Kg.	
BW	D	A	B	L	Rotating Parts	Total	A	B	L	Rotating Parts	Total	A	B	L	Rotating Parts	Total
*600	88.9	700	708	742	7.4	10.8	350	358	382	4.4	6.1	235	243	267	3.4	4.6
	114.3				10.1	13.6				5.9	7.6				4.5	5.6
650	88.9	750	758	792	7.9	11.5	380	388	412	4.7	6.5	250	258	282	3.6	4.8
	114.3				10.7	14.4				6.2	8.1				4.7	5.9
*750	114.3	850	858	892	12.0	16.1	415	423	447	6.7	8.7	280	288	312	5.0	6.4
	139.7				15.6	19.9				8.6	10.6				6.4	7.8
800	114.3	950	958	992	13.1	17.8	465	473	497	7.3	9.5	315	323	347	5.5	7.0
	139.7				17.3	21.9				9.4	11.7				7.0	8.5
	165.1				20.4	25.0				11.0	13.4				8.2	9.8
*900	114.3	1050	1058	1092	14.4	19.5	530	538	562	8.0	10.6	350	358	382	5.9	7.6
	139.7				18.9	24.0				10.5	13.0				7.6	9.3
	165.1				22.3	27.5				12.3	15.0				8.9	10.6
1000	114.3	1150	1158	1192	15.6	21.2	600	608	632	8.9	11.8	380	388	412	6.2	8.1
	139.7				20.5	26.1				11.6	14.5				8.0	10.0
	165.1				24.2	29.9				13.7	16.6+				9.5	11.3
1200	114.3	1400	1408	1442	18.6	25.4	700	708	732	10.1	13.5	465	473	497	7.3	9.5
	139.7				24.6	31.4				13.2	16.6				9.4	11.7
	165.1				29.0	35.9				15.6	19.0				11.1	13.4
1400	114.3	1600	1608	1642	21.0	28.8	800	808	832	11.3	15.2	530	538	562	8.0	10.6
	139.7				27.8	35.6				14.8	18.7				10.5	13.0
	165.1				32.9	40.7				17.5	21.4				12.3	14.9
*1500	114.3	1700	1708	1742	22.2	35.5	850	858	882	11.9	16.0	565	573	597	8.5	11.3
	139.7				29.4	37.7				15.6	19.8				11.0	13.9
	165.1				34.8	43.0				18.5	22.6				13.0	15.8

*1. Belt Width not covered under IS.

2. Rollers with 76.2 mm, 101.6 mm, 127 mm & 152.4 mm. Dia can be made as per Customers specific requirement.

3. Impact Idlers will have rubber Rings (Shore Hardness 65°±50°) press fitted on the Ø76.1, 88.9 / 114.3 dia tube and locked at both ends.

4. Weight of Roller based on medium duty tube.

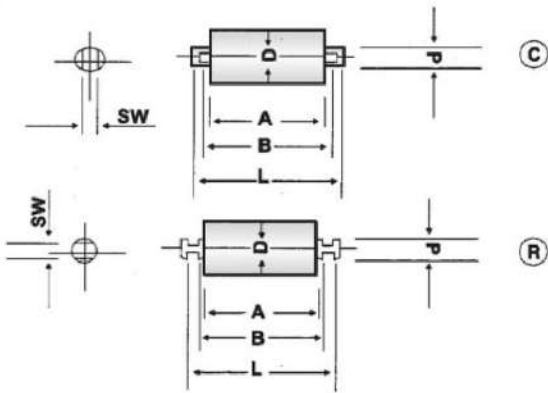

SERIES - KIC 206							
STANDARD - IS : 8598 / 4776							
TUBE DIA & THICKNESS AS PER IS : 9295							
			L	M	H	E.H.	
1)	114.3	dia	-	3.65	4.5	5.4	6.3
2)	139.7	dia	-	4.5	4.85	5.4	6.3
3)	165.1	dia	-	4.5	4.85	5.4	6.3
				d	=	30 mm	
				sw	=	22 mm	

All diamention are in mm.

SERIES : KIC : 6206 / 420206

Belt Width	Roller Dia.	Flat Top / Return Idler					2 Roll Top Idler					3 Roll Top Idler				
		Dimension in mm			Wt. In Kg.		Dimension in mm			Wt. In Kg.		Dimension in mm			Wt. In Kg.	
BW	D	A	B	L	Rotating Parts	Total	A	B	L	Rotating Parts	Total	A	B	L	Rotating Parts	Total
800	114.3	950	958	992	13.3	20.8	465	473	497	7.4	11.0	315	323	347	5.6	8.0
	139.7				17.4	25.0				9.6	13.2				7.1	9.6
	165.1				20.6	28.0				11.2	14.9				8.4	10.8
*900	114.3	1050	1058	1092	14.5	22.8	530	538	562	8.2	12.4	350	358	382	6.0	8.8
	139.7				19.0	27.4				10.6	14.8				7.7	10.4
	165.1				22.4	30.8				12.5	16.7				9.0	11.8
1000	114.3	1150	1158	1192	15.7	24.9	600	608	632	9.0	13.8	380	388	412	6.4	9.4
	139.7				20.7	29.9				11.8	16.5				8.2	11.2
	165.1				24.4	33.6				13.8	18.6				9.6	12.6
1200	114.3	1400	1408	1442	18.7	29.9	700	708	732	10.3	15.8	465	473	497	7.4	11.0
	139.7				24.7	35.9				13.4	18.9				9.6	13.2
	165.1				29.2	40.4				15.8	21.3				11.2	14.9
1400	114.3	1600	1608	1642	21.1	33.9	800	808	832	11.5	17.8	530	538	562	8.2	12.4
	139.7				28.0	40.7				15.0	21.3				10.6	14.8
	165.1				33.0	45.8				17.7	24.0				12.5	16.7
1500	114.3	1700	1708	1742	22.4	35.9	850	858	882	12.0	18.8	565	573	597	8.6	13.0
	139.7				29.6	43.1				15.8	22.5				11.2	15.6
	165.1				35.0	48.5				18.6	25.4				13.2	17.6
*1600	114.3	1800	1808	1842	23.6	37.9	900	908	932	12.7	19.8	600	608	632	9.0	13.8
	139.7				31.2	45.6				16.6	23.7				11.8	16.5
	165.1				36.9	51.2				19.6	26.7				13.8	18.6
1800	114.3	2000	2008	2042	26.0	42.0	1000	1008	1032	13.9	21.8	670	678	702	9.9	15.2
	139.7				34.4	50.4				18.2	26.1				12.9	18.2
	165.1				40.7	56.7				21.5	29.4				15.2	20.5
2000	114.3	2200	2208	2242	28.4	46.0	1100	1108	1132	15.1	23.6	750	758	782	10.9	16.8
	139.7				37.7	55.2				19.9	28.3				14.2	20.1
	165.1				41.3	58.8				23.4	31.9				16.7	22.6

1. Belt Width not covered under IS.

2. Rollers with 76.2 mm, 101.6 mm, 127 mm & 152.4 mm. Dia can be made as per Customers specific requirement.

3. Impact Idlers will have rubber Rings (Shore Hardness 60°±50°) press fitted on the Ø76.1, 88.9 / 114.3 dia tube and locked at both ends.

4. Weight of Roller based on medium duty tube.

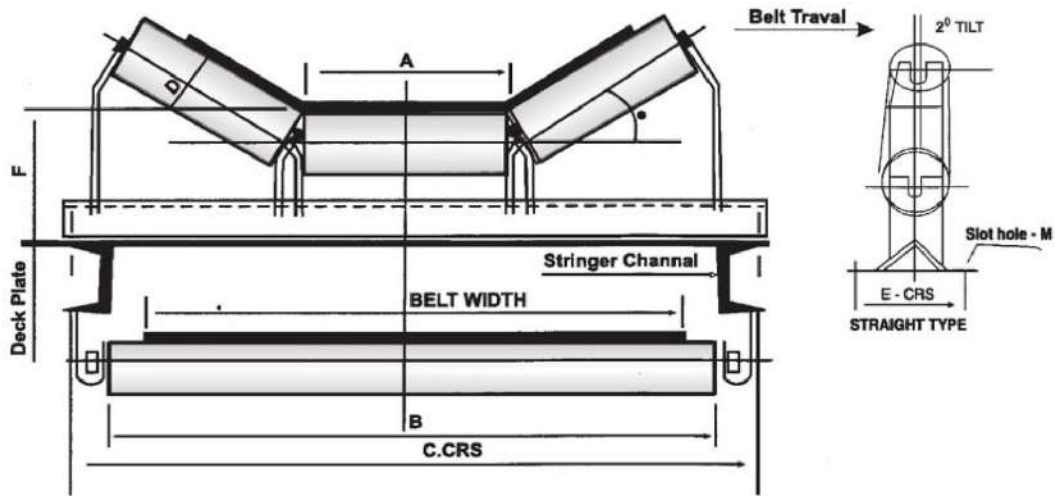

20°, 30°, 35°, Troughing Idler Set (Plain & Impact Type with Stringer & Return Idler)

Belt Width	Dimensions in mm.				F				M (Slot Size)
	A	B	C	E	Upto 88.9 D	Upto 114.3 D	Upto 139.7 D	Upto 165.1 D & above	
*400	160	500	690	165 / 200	200	225	-	-	14 x 25
450	180	550	740	165 / 200	200	225	-	-	14 x 25
500	200	600	790	165 / 200	200	225	-	-	14 x 25
600	235	700	890	165 / 200	200	225	-	-	14 x 25
650	250	750	940	200	200	225	-	-	18 x 30
*750	290	850	1040	200	200	225	275	-	18 x 30
800	315	950	1090	200	200	225	275	290	18 x 30
*900	350	1050	1190	200	200	225	275	290	18 x 30
1000	380	1150	1290	200	200	225	275	290	18 x 30
1200	465	1400	1490	200	200	240	275	290	18 x 30
1400	530	1600	1690	200	-	240	275	290	18 x 30
*1500	565	1700	1775	200	-	240	275	290	22 x 40
1600	600	1800	1900	200	-	240	275	290	22 x 40
1800	670	2000	2100	200	-	240	275	290	22 x 40
2000	750	2200	2300	200	-	240	275	290	22 x 40

* Belt Width not covered under IS.
All dimensions are in mm.

QUALITY POLICY

KIC Standard Conveyor Pulleys are fabricated from steel shells / plates with welded end plates and bosses keyed / fitted direct / through Tapper sleeve on the shaft.

Shell thickness before machining - from 8 to 20 mm. The distance over bosses can be made to suit any requirement, however, we recommend that this be as wide as possible to keep the dimension between the boss and bearings to minimum to reduce shaft flexing.

Drive / Tail / Take-up pulleys have machined crowned faces to train and reduce wear on Belt. Other pulleys are with straight face.

Plain or grooved rubber lagging can be furnished when additional friction is required between belt and pulley or if the application calls for the same such as handling wet / abrasive materials etc.

All Pulleys are concentric and statically balanced and confirm to IS:8531

Belt Width B.W. mm	Standard Dia 'D' mm	Face mm 'L' mm	Shaft Dia 'd' mm
400	-217, 271, 321, 353, 400, 454, 500, 630 800, 1000, 1250, 1400 and 1600 mm. -	500	- Available from 45 mm. To 200 mm. -
* 450		550	
500		600	
* 600		700	
650		750	
* 750		850	
800		950	
* 900		1050	
1000		1150	
1200		1400	
1400		1600	
* 1500		1700	
1600		1800	
1800		2000	
2000		2200	

* Belt Width not covered under I.S.S.

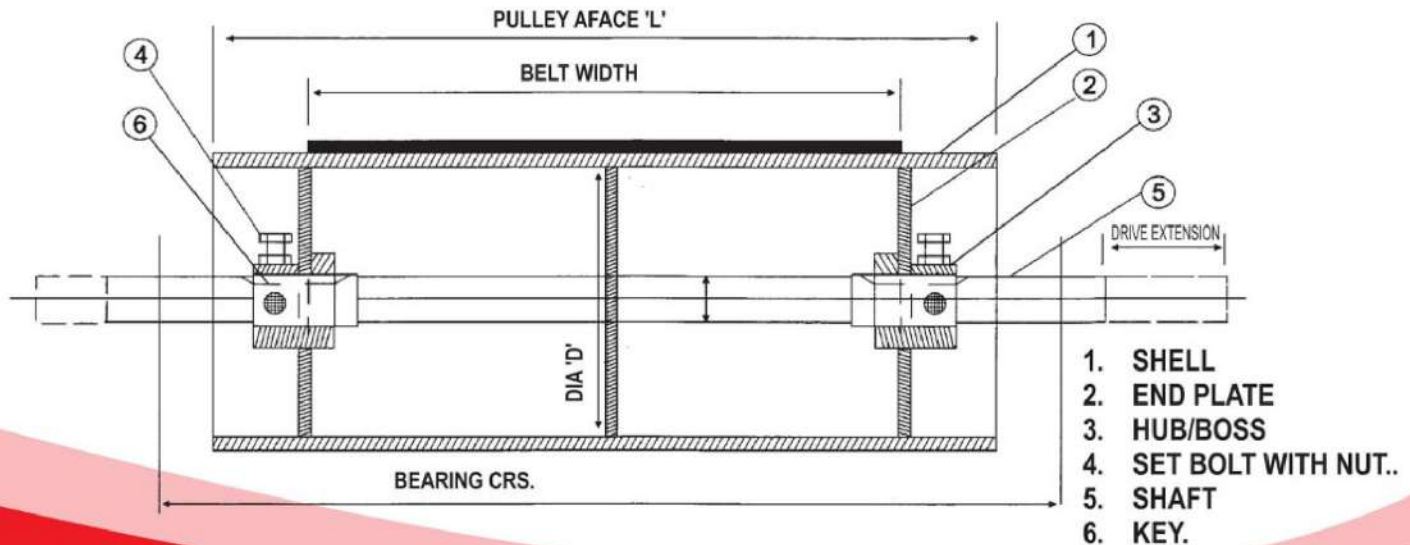

Sheet Metal Jobs. Like

a. Pressed Steel Bearing Housing

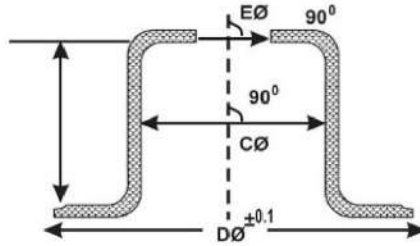

Bearing	-0.03 -0.00 CØ	+0.010 B	EØ ±0.2
6204/ 420204	47	43	27
6205 / 420205	52	44	32
6306	72	45.5	37
6307	80	58	80
6308	40	55.5	47

TubeØ	DØ -0.10
63.5	58.5
76.1	71
88.9	84.5
101.6	97.5
108	103.5
114.3	109.5
127	122.5
139.7	135
152.4	147
159	151
168.3	163

b. Pressed Steel dust covers

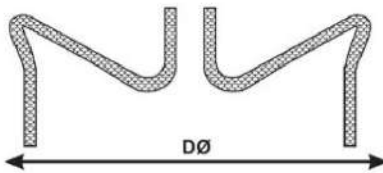

Bearing	DØ ±0.3
6204	47Ø
6205	52Ø
6206	62
6306	72
6307	80
6308	90

Holdback S MSR Gearbox



Shaft Mounted Gearbox



Holdback S MSR Gearbox With Motor Stand



Cement Plant



Crusher Plant



Fertilizer Plant



Mining Conveyor



Transport Conveyor



Bulk Material Handling Conveyor



Port Conveyor



Power Plant Conveyor





988 68 737 89
9113 222 547



9513 705 559



info@shrirajeshwariindustries.com



www.shrirajeshwariindustries.com



SHRI RAJESHWARI
Industrial Essentials

Authorised Dealer

#357, 2nd Floor, 60 Feet road,
(Opp) Gold's Gym, Rajarajeshwari nagar,
Bangalore- 560 098